



Mod. CMS-300



Mod. CMS-550

Dough Roller - Model CMS-300/550

Instruction Manual

Instruction Manual

Index



1. Introduction	02
1.1 Safety	02
1.2 Main components	02
1.3 Technical Characteristic	03
2. Installation and Pré-Operation	03
2.1 Installation	03
2.2 Pre-operation	04
2.3 Proceedings for feeding	05
3. Regular Operation	05
3.1 Switching on	05
3.2 Dough thickness control	06
3.3 Cleaning	06
4. General Safety Rules	07
4.1 Basic operational practice	07
4.2 Precautions and remarks before switching on the machine	08
4.3 Routine Inspection	09
4.4 Operation	09
4.5 After work is done	10
4.6 Maintenance Operation	10
4.7 How to proceed in case of EMERGENCY	10
4.8 Warnings	11
5. Problem Analysis and Solutions	11
5.1 Problems, causes and solutions	11
5.2 Exploded Drawing CMS-300	12
5.3 Spare Part List CMS-300	13
5.4 Exploded Drawing CMS-550	14
5.5 Spare Part List CMS-550	15
6. Electrical Diagram	16

1. INTRODUCTION

1.1 Safety

When improperly used the Dough Roller Model CMS-300/550 is a potentially DANGEROUS equipment. Never place your hand inside the upper opening through which the dough is introduced to feed the machine. Cleaning and maintenance or any other operation with the machine shall be carried out by trained personel. In order to avoid accidents follow the instructions below:

1.1.1 Be sure the machine is plugged off the electric network when cleaning, maintenance or any service is being made.

1.1.2 Never use direct water spray on the machine.

1.2 Main Components

The Dough Roller Model CMS-300/550 is a machine to be used on a bedplate or a solid table to roll different kinds of dough.

Most of the components which are part of the machine, are manufactured with high performance raw materials : stainless steel, aluminum or plastic.

Pic - 01

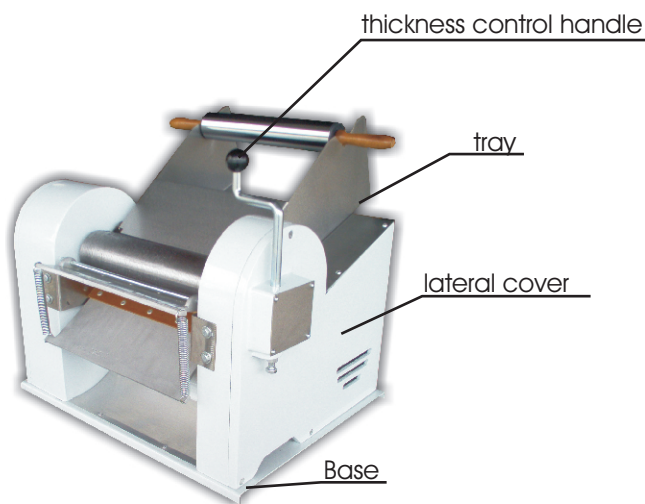

5.5 Spare Part List CMS-550

CÓDIG	DESCRICAÇÃO DO COMPONENTE	UM	CÓDIGO	DESCRICAÇÃO DO COMPONENTE	UM
00027-2	PE 3/8 "x 7/8"	PC			
00037-0	PCA SEX UNC 1/4" ZB	CE	00947-4	PINO FIX.TAMPA CARC.DIR.	PC
00038-8	ARR L 1/2" ZB	CE	00955-5	POLIA MOTORA CMS-200/300	PC
00045-0	REBITE PRESSAO AD-423-S	MI	00956-3	CORREIA A 29	PC
00051-5	PCA SEX W 1/2" ZB	CE	01044-8	PFS SEX UNC5/16x5/8 RTZB	CE
00091-4	PFS ACC UNC1/4"x7/8" RTF	CE	01213-0	TERM. PRE-ISOL.EF-4228	MI
00094-9	PFS SEX UNC5/16x1.1/4RTZB	CE	01259-9	CORRENTE CMS-200/300	PC
00095-7	PFS FCH UNC1/4"x3/4" RTZB	CE	01661-6	ESFERA C/FURO 1/2"	PC
00097-3	ARR. BALANC.8x30x1.5mm	CE	01735-3	MANIVELA REVER.COMPL.CMS	PC
00100-7	ARR L 1/4"x1,6 ZB	CE	01736-1	TAMPA DE PROTECAO-CMS	PC
00101-5	ARR L 3/8" ZB	CE	01749-3	ENG.GUIA/TENS.Z-14 C/DIST	PC
00107-4	PCA SEX UNC 5/16" ZB	CE	01752-3	CORPO DA MANIVELA-CMS	PC
00108-2	PCA SEX UNC 3/8" ZB	CE	01754-0	PINHAO Z-12 CMS-200-300	PC
00119-8	ARR L 5/16" ZB	CE	01835-0	FIO INTERNO SERRAS/CMS	PC
00122-8	PFS SEX UNC3/8x1.1/4 RTZB	CE	02216-0	ENG.GUIA/TENSORA COMPLETA	PC
00124-4	PASSADOR FIO MOLDE 092223	PC	02918-1	MOTOR 1CV 50Hz	PC
00167-8	LOGOTIPO SKYMSSEN GR.ADES.	DE	02943-2	ARR L 5/8" ZB	CE
00208-9	ROLAMENTO 6006 Z	PC	02949-1	TERM. PRE-ISOL.NA-4503	MI
00219-4	PFS SEX UNC3/8"x2" RTZB	CE	03678-1	CAPINHA DE NYLON CN-4478	MI
00241-0	PFS SEX UNC3/8"x1" RTZB	CE	04698-1	CB.3x1,5mm2C/PG90 2PR1FTF	PC
00290-9	PFS ASC UNC1/4"x1/2" F	CE	05504-2	ETIQ.ATENCAO 110/220/380V	CE
00306-9	PINO ELAST.6x40 DIN 1481	CE	08268-6	MANCAL PINHAO COMP.CMS300	PC
00420-0	PFS FRD UNC5/32x5/16 RTZB	CE	08572-3	ENGRENAGEM GUIA COMPLETA	PC
00430-8	PFS B.4.2x25 DIN 7971 ZB	CE	09637-7	ETIQ.IDENTIF.MOTOR/RESIST	PC
00504-5	REBITE PRESSAO AD-650-S	MI	09764-0	BASE DE CHAPA CMS-550	PC
00543-6	PFS FRD UNC3/16"x3/8 RTZB	CE	09766-7	SEPARADOR INFER.CARCACAS	PC
00544-4	PFS SEX UNC1/4"x5/8" RTZB	CE	09767-5	SEPARADOR SUPER.CARCACAS	PC
00545-2	PFS SEX UNC5/16x1.1/2RTZB	CE	09768-3	ROLO INFERIOR	PC
00556-8	PFS ASC UNC5/16"x1/2" F	CE	09769-1	ROLO SUPERIOR	PC
00647-5	CABO DE MADEIRA	PC	09770-5	EIXO EXCENTRICO	PC
00648-3	PFS FRA UNC 1/2x5.1/2 RPZB	CE	09802-7	ROLO DE MADEIRA	PC
00786-2	ROLAMENTO 6203	PC	09821-3	SUPORTE RASPADOR INFERIOR	PC
00853-2	ENGR.CENTRAL Z-68 BA-30	PC	09822-1	SUPORTE RASPADOR SUPERIOR	PC
00869-9	MANCAL PINHAO BA-30/CMS	PC	09825-6	CHAPA RASPADOR SUPRE INF.	PC
00871-0	POLIA MOVIDA BA-30/CMS-30	PC	09826-4	HASTE SUPORTE RASP.C/ZINC	PC
00894-0	TAMPA LAT.DIR. CMS-300	PC	09830-2	CHAPA DE PROTECAO CMS-550	PC
00895-8	TAMPA LAT.ESQU. CMS-300	PC	09836-1	PARAFUSO SEPARADOR	PC
00906-7	PFS ACC UNC1/4"x3/4" RTF	CE	09839-6	RASPADOR INFERIOR	PC
00913-0	BUCHA DA ENGRN.SUPERIOR	PC	09840-0	RASPADOR SUPERIOR	PC
00915-6	BRACO DO ROLO SUPERIOR	PC	09900-7	ROLAMENTO 6006 DDU	PC
00916-4	COROA CMS-200-300	PC	09901-5	ROLAMENTO 6204 DDU	PC
00917-2	ENGR.DO ROLO SUPER. Z-17	PC	10241-5	CHAVE SELETORA 10A S/ADES	PC
00923-7	PFS SEX W1/2"x50mm P/ENG.	CE	10349-7	POLIA COM CUBO PARA FREIO	PC
00926-1	HASTE TENSORA CMS-200/300	PC			
00929-6	MOLA ENGRENAGEM TENSORA	PC			
00939-3	MOLA DO RASPADOR	PC			
00941-5	MANIVELA ACO 1/2" C/ZINC.	PC			
00942-3	PARAFUSO S/FIM C/TT	PC			
00943-1	PINO FIX.PARAF.S/FIM	PC			
00944-0	TAMPA DA CAIXA ENGRENAGEM	PC			

The power cable is provided with a plug with two round pins and a grounding wire.

It is mandatory that the three points be connected before the machine is started.

Pic - 03

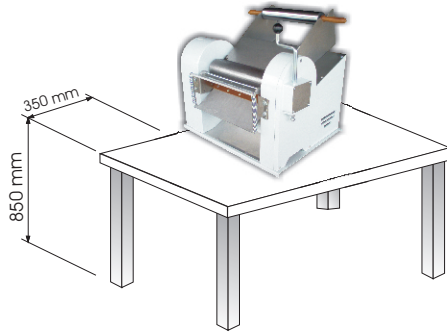

2.2 Pre Operation

Important
Under no circumstances do the cleaning when the machine is working.

First make sure the Dow Roller is firm in its position. Clean the rolls with a dry cloth and if necessary with a plastic slice.

Pic - 04



5.3 Spare Part List CMS-300

CODIG	DESCRICAO DO COMPONENTE	UM	CODIGO	DESCRICAO DO COMPONENTE	UM
PE 3/8 "x 7/8"		PC	00947-4	PINO FIX.TAMPA CARC.DIR.	PC
PFS ASC UNC1/4"x3/8" F		CE	00948-2	GABINETE CMS-300	PC
PCA SEX UNC 1/4" ZB		CE	00954-7	MOTOR 1CV 60Hz	PC
ARR L 1/2" ZB		CE	00955-5	POLIA MOTORA CMS-200/300	PC
REBITE PRESSAO AD-423-S		MI	00956-3	CORREIA A 29	PC
PCA SEX W 1/2" ZB		CE	00957-1	CALHA CMS-300	PC
PFS ACC UNC1/4"x7/8" RTF		CE	00959-8	SUPORTE ESQUERDO DA CALHA	PC
PFS SEX UNC5/16x1.1/4RTZB		CE	00960-1	SUPORTE DIREITO DA CALHA	PC
PFS FCH UNC1/4"x3/4" RTZB		CE	01044-8	PFS SEX UNC5/16x5/8 RTZB	CE
PFS SEX UNC5/16"x2" RTZB		CE	01213-0	TERM. PRE-ISOLEF-4228	MI
ARR L 1/4"x1.6 ZB		CE	01259-9	CORRENTE CMS-200/300	PC
ARR L 3/8" ZB		CE	01633-0	CHAPA RASPADOR CMS/CMF300	PC
PASSADOR FIO 5.2-1199		PC	01634-9	RASPADOR SUPERIOR CMS-300	PC
PCA SEX UNC 5/16" ZB		CE	01661-6	ESFERA C/FURO 1/2"	PC
PCA SEX UNC 3/8" ZB		CE	01735-3	MANIVELA REVER.COMPL.CMS	PC
ARR L 5/16" ZB		CE	01736-1	TAMPA DE PROTECAO-CMS	PC
PFS SEX UNC3/8x1.1/4 RTZB		CE	01743-4	CHAPA DE PROTECAO-CMS-300	PC
CHAVE EL.CS-301B MAR-GIR.		PC	01749-3	ENG.GUIA/TENS.Z-14 C/DIST	PC
REBITE PRESSAO AD-450-S		MI	01750-7	ENGR.ROLO INF.Z-17 C/DIST	PC
LOGOTIPO SKYSEN GR.ADES.		DE	01752-3	CORPO DA MANIVELA-CMS	PC
ROLAMENTO 6006 Z		PC	01756-6	SUPORTE DA MANIVELA-CMS	PC
ABRACADEIRA K22 (I-50R)		CE	01835-0	FIO INTERNO SERRAS/CMS	PC
PASSADOR FIO MOLDE 092231		PC	01844-9	ETIQ.ON/OFF P/CH.ALAV.MET	DE
PFS SEX UNC3/8"x2" RTZB		CE	02031-1	CAPINHA DE NYLON CN-4472	MI
REBITE PRESSAO AD-440-S		MI	02216-0	ENG.GUIA/TENSORA COMPLETA	PC
ROLAMENTO 6204 Z		PC	02734-0	CHAPA RASPADOR.RECOR.T-CMS	PC
PFS SEX UNC3/8"x1" RTZB		CE	02943-2	ARR L 5/8" ZB	CE
PFS ASC UNC1/4"x1/2" F		CE	02946-7	PARAFUSO SEPARADOR-CMS	PC
PINO ELAST.6x40 DIN 1481		CE	03201-8	TERM. ELET. 165019 6mm	MI
CHAVE EL.14223 A1B1E3G		PC	03678-1	CAPINHA DE NYLON CN-4478	MI
PFS FRD UNC5/32x5/16 RTZB		CE	04287-0	CB.3x1,5mm2 C/PLUG/TERM.	PC
EIXO EXCENTRICO		PC	04698-1	CB.3x1,5mm2C/PG90 2PRI1FTF	PC
PFS SEX UNC3/8x1.1/2 RTZB		CE	05504-2	ETIQ.ATENCAO 110/220/380V	CE
PFS B.4,2x25 DIN 7971 ZB		CE	08268-6	MANCAL PINHAO COMP.CMS300	PC
REBITE PRESSAO AD-650-S		MI	08459-0	CONJ.CARC./TAMPA LAT.DIR.	PC
PFS FRD UNC3/16"x5/8" RTZB		CE	08460-3	CONJ.CARC./TAMPA LAT.ESQ.	PC
PFS SEX UNC1/4"x5/8" RTZB		CE	08572-3	ENGRENAGEM GUIA COMPLETA	PC
PFS SEX UNC5/16x1.1/2RTZB		CE	09637-7	ETIQ.IDENTIF.MOTOR/RESIST	PC
PFS ASC UNC5/16"x1/2" F		CE	09660-1	TERM. PRE-ISOLET-4259(C)	MI
CABO DE MADEIRA		PC	09814-0	ARRUELA DISTANCIADORA	PC
PFS FRA UNC1/2x5.1/2 RPZB		CE	09900-7	ROLAMENTO 6006 DDU	PC
ROLAMENTO 6203		PC	09901-5	ROLAMENTO 6204 DDU	PC
ENGR.CENTRAL Z-68 BA-30		PC	10242-3	CHAVE SELETORA 24A SADES	PC
MANCAL PINHAO BA-30/CMS		PC	10700-0	BASE DE CHAPA COMPLETA	PC
POLIA MOVIDA BA-30/CMS-30		PC	10706-9	ROLO INFERIOR CMF/CMS-300	PC
TAMPA LAT.DIR. CMS-300		PC	10707-7	FLANGE DO ROLO SUPERIOR	PC
TAMPA LAT.ESQU. CMS-300		PC	10752-2	CALHA	PC
CARCACA ESQUERDA CMS-300		PC	10756-5	ROLO SUPERIOR CMS/CMF-300	PC
CARCACA DIREITA CMS-300		PC	10764-6	HASTE SUPRASPADOR ZINC.	PC
SEPARADOR SUPER.CARCACAS		PC	10767-0	GABINETE	PC
SEPAR.INFER.DAS CARCACAS		PC	10769-7	ANEL 30x1,5 DIN 471	CE
ROLO INFERIOR CMS-300		PC	10776-0	SEPARADOR SUPER.DAS CARC.	PC
ROLO SUPERIOR CMS-300		PC	10778-6	SEPARADOR INFER.DAS CARC.	PC
PFS ACC UNC1/4"x3/4" RTF		CE	10779-4	TUBO ROLO SUPER. C/FLANGE	PC
CHAPA DE ACABAMENTO CMS		PC	10781-6	ENGR.ROLO INF.Z-17 C/DIST	PC
ENGR.CENTRAL Z-68 CMS-300		PC	10932-0	ADES.CHAVE 24A 60Hz-B SKY	PC
ROLO DE MADEIRA CMS-300		PC	12565-2	ROLAMENTO 6204 RS1 DIN625	PC
BUCHA DA ENGREN.SUPERIOR		PC	12920-8	CHAPA PROTECAO CMS-300	PC
BRACO DO ROLO SUPERIOR		PC	12925-9	CHAVE SELETORA COMPLETA	PC
COROA CMS-200-300		PC	13055-9	CONJ.CARC./TAMPA LAT.ESQ.	PC
ENGR.DO ROLO SUPER. Z-17		PC	13056-7	CONJ.CARC./TAMPA LAT.DIR.	PC
ENGREN.GUIA/TENSORA Z-14		PC	13131-8	CONJ. CALHA/GABINETE	PC
PFS SEX W1/2"x50mm P/ENG.		CE	13797-9	ENG.GUIA/TENSORA COMPLETA	PC
HASTE TENSORA CMS-200/300		PC	13821-5	CHAVE TECL.30223 M2FT2E3G	PC
DISTANC.ENGR.GUIA/TENSORA		PC	15261-7	ANEL DO ROLO INFERIOR	PC
MOLA ENGRENAGEM TENSORA		PC	15268-4	ROLO SUPERIOR CMS/CMF-300	PC
BASE CMS-300 PINTADA		PC	15599-3	PFS B.3,5x9,5 DIN 7971 In	CE
PFS SEX UNC1/4x1.1/2 RTZB		CE	15695-7	CHAPA DE RETENCAO	PC
SUPORTE RASPADOR SUPERIOR		PC	15865-8	CONJ. CALHA/GABINETE 60HZ	PC
SUPORTE RASPADOR INFERIOR		PC	15866-6	GABINETE 60HZ	PC
HASTE DOS SUPRASC/ZINC		PC	16540-9	PROTECAO DO MOTOR	PC
MOLA DO RASPADOR		PC	16715-0	CHAPA ACABAM. COMPLETA	PC
RASPADOR INFERIOR		PC	17581-1	TERM.POSITIV LOCK 0,5A1,5	MI
MANIVELA ACO 1/2" C/ZINC.		PC	17582-0	CAPA P/TERMINAL FEMEA	MI
PARAFUSO S/FIM C/TI		PC	18321-0	CONJ. CALHA/GABINETE	PC
PINO FIX.PARAF.S/FIM		PC	18322-9	ENCOSTO DIREITO CMF-300	PC
TAMPA DA CAIXA ENGRENAGEM		PC	18323-7	ENCOSTO ESQUERDO CMF-300	PC
PFS FRD UNC5/32x1/4 RTZB		CE	22619-0	CHAPA PROTECAO CMS-300	PC

5.2 Exploded Drawing CMS-300

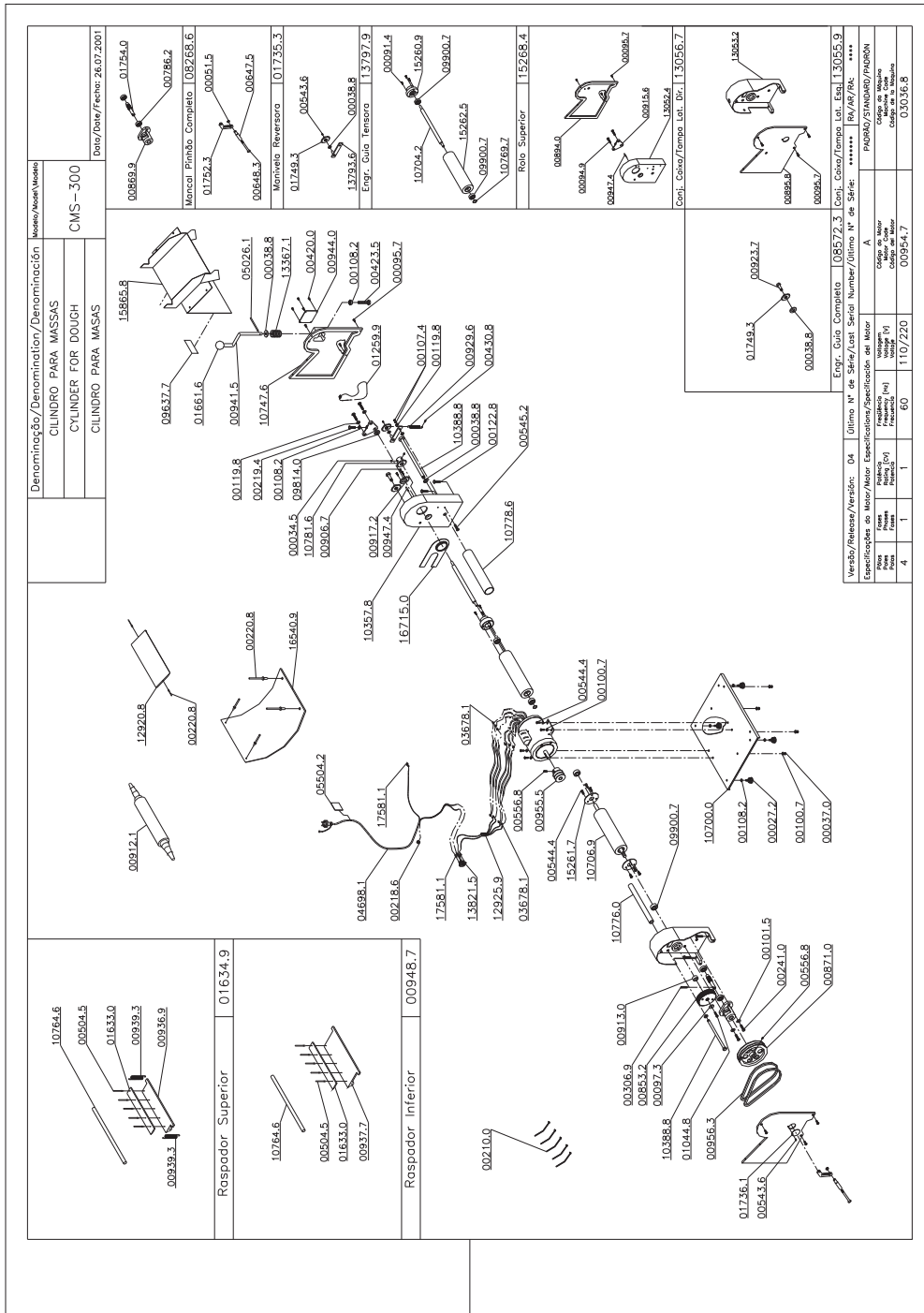

2.3 Feeding Procedures

Important
 Under no circumstances use your hands to directly put or remove any portion of dough in between the cylinders.

To feed the Dough Roller the product to be processed has to be placed on the receiving tray leading the dough until it is pulled by the rollers. Make sure the hands are away from the rollers.

Pic - 05

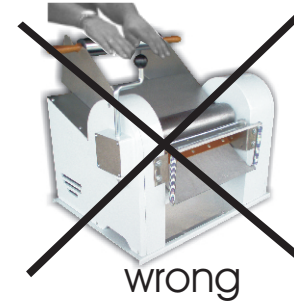

Pic - 06



3. NORMAL OPERATION

3.1 Switching On

Important
 Wait until the rollers come to a complete stop. The machine operates in silence. Do not place any objects such as knives, spoons or other when the machine is not in operation.

To start the machine press the button of the ON/OFF switch, on the upper side of the machine .

3.2 Setting the thickness of the dough

In order to determine the thickness of the dough, turn the thickness control handle according to the desired measure.

Pic - 07



3.3 Cleaning

Important

Never do any cleaning when machine is plugged to the electrical network. To do the cleaning unplug it . Be sure the rollers are completely motionless.

For cleaning turn the machine off, unplug it from the electrical network. All parts that were touched by dough will have to be cleaned.

3.3.1 Clean all parts that have contact with the dough with a dry cloth.

3.3.2 Never use objects such as knives, forks and other cutting or punching tools to remove dough that is stuck in between the rollers. Use a plastic slice for cleaning or removing dough.

4.8 Warnings

The electrical and mechanical maintenance has to be performed by skilled personnel. The person in charge has to be sure that the machine is under perfect working and safe conditions before it is switched on.

5. PROBLEMS ANALYSIS AND SOLUTIONS

5.1 Problems, causes and solutions

The CMS -300 Dough Roller was designed to need minimum maintenance however some performance failures may occur due to operational wearing.

Please refer to Table- 02 below in which the main possible problem/solution situations are described.

Besides the Company is ready to assist you through your Dealers as well as the Company Technical Assistance network.

Table - 02

*The laminated product got stuck in between the rollers	*Deregulated scrapers	* Call technical assistance
* Rollers stop during operation	*on/off button with bad contact *Cord or outlet with bad contact *No power	*Check if machine is plugged in outlet * Call technical assistance *Check if cord is in perfect conditions, check the pins of the plug

4.5 After work is done

4.5.1 Always clean the machine after the operation.
UNPLUG THE MACHINE FROM THE OUTLET.

Never clean the machine unless the rollers have come to a COMPLETE STOP.

Replace all parts on its proper position before turning it on again.

Check level of oil.

When checking the tension of the rubber belt(s) and chain(s) never INTRODUCE your fingers between the belt(s) and the pulleys , neither between the (chain(s)) and the gears.

4.6 Maintenance Procedure

Any maintenance operation is dangerous when the machine is on. TURN IT OFF BY UNPLUGGING THE MACHINE FROM THE OUTLET.

4.7 EMERGENCY - How to proceed

In case of EMERGENCY turn the machine off IMMEDIATELY by pressing on the on/off switch on the upper part of the machine. The rollers will stop right away. Then you turn the thickness control handle to its maximum width thus allowing a wider distance between the rollers.

IMPORTANT

Immediately unplug the machine from the outlet in case of emergency. Never turn the machine on when the reversion handle is fixed in the pinion.

Important

After the machine has been used be sure it is turned off and scatter a thin layer of margarine or fat, both saltless, on the rollers to keep them from rusting .

4. GENERAL SAFETY RULES

General Safety Rules were developed to more adequately clarify and instruct operators and maintenance personnel.

The machine has to be handed over to the operator in good working conditions. Also the operator has to be properly instructed concerning the use and safety of the machine by the Dealer. The operator should not use the machine before getting fully familiar with the whole contents of this Instruction Manual.

4.1 Basic Operational Practice

4.1.1 CAUTION

Some parts are connected to electricity and may cause fatality when touched due to high voltage.

Never touch buttons, switches and keys with wet hands, shoes or clothes. Such recommendation not being followed may cause electric shocks and even fatality.

4.1.2 Warning

It is important to know exactly the place where the on/off switch is installed on the machine without having to search for it in case of emergency.

Before any maintenance procedure, be sure the machine is plugged off the network.

A safe and large working area shall be provided to avoid dangerous falls .

Water and oil on the floor will turn it slippery and dangerous. Be sure the floor is clean and dry.

Before turning on any switch (buttons, keys and switches) be sure the operation is correct. Check this manual if any doubt arises.

Never touch or give any manual command at random .

If the operation is performed by more than one operator be sure that signs of communication are clear and well understood. A following operation can proceed only when the sign between operators was made and understood.

4.1.3 General

Immediately turn the machine off in case of electrical power failure.

Use only recommended oil lubs and grease or equivalent.

Avoid mechanical shocks which may affect the good performance of the machine.

Avoid the penetration of water, dirt or dust on electrical or mechanical components of the machine.

Do not change original characteristics of the machine.

Preserve all warning and identification signs. Do not remove any and make sure the stickers are clean and clear. Contact your nearest Technical Assistant if any has been removed or torn.

4.2 Care and observations before switching on the Dough Roller

Important

Read carefully and with attention all the contents of this Manual before turning the machine on. Be sure all instructions were well understood. If any doubts arise contact your next responsible person , or contact the Dealer.

Damaged electrical wire or cable may cause leakage and electrical shocks. Be sure to check the conditions of the wiring.

4.2.2 Warning

Be sure that the contents of this manual are all well and fully understood. Every operational function or proceeding has to be clear.

The operator has to be well aware of the functions of each key or button that is being touched. The operator has to know which is the right command to be started.

The electrical cable in use has to be adequate to hold the power of the motor

Electrical cord on the floor or near the machine must be protected , to avoid short circuits .

Oil reservoirs have to be on their adequate level. Check and add oil when necessary.

4.3 Routine Inspection

When checking the tension of the rubber belt(s) DO NOT put your fingers between the belts and neither between the gears.

Check if motor(s) , sliding and turning parts are producing abnormal noises.

Check tension of rubber belt(s) and chain(s), and change the whole set if any belt or chain is worn out .

DO NOT introduce your fingers between the belt(s) and the pulley (ies) , neither between the chain(s) and the gear (s).

4.4 Operation

Do not work with loose long hair, that could get caught by parts of the machine and thus cause serious accidents. Tight the hair behind and above the head, or cover them with a scarf .

Only qualified and well trained operators may operate the machine.

NEVER operate the machine without all original safety devices in perfect conditions.